



# SUNCOAST

## POLYCARBONATE ROOF



BETTER  
OUTDOOR  
LIVING





Creating exceptional  
residential enclosures  
for any application

## | TABLE OF CONTENTS

04 ABOUT US

05 PRODUCT: POLYCARBONATE ROOF

11 ACCESSORIES

13 MANUFACTURING

14 POWDER COATING

15 THE TEAM





## | ABOUT US

### Pushing the boundaries in luxury outdoor living

Suncoast is a premier manufacturer, supplier and builder of luxury outdoor enclosures. With over 30 years of experience building in the harshest Canadian environments, you can count on dependable quality for your next deck, patio, enclosure or project.

#### MANUFACTURING

Suncoast takes control of the manufacturing process to ensure the highest quality product tailored perfectly to your custom application. From cutting and coating to kitting and shipping, the Suncoast team ensures the reliable delivery of a structure built to last for many years.

#### PRODUCT DEVELOPMENT

We strive to be at the leading edge of the industry with respect to technology and style. That's why our product development team is continuously sourcing new profiles, parts and smart options to engineer functional and beautiful products.





## | POLYCARBONATE ROOF

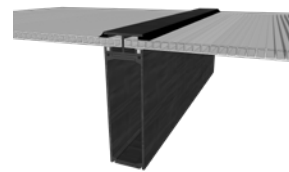

Completely seal and weather proof your patio with a Suncoast Polycarbonate roof. Every roof structure is designed and engineered to withstand local snowloads.

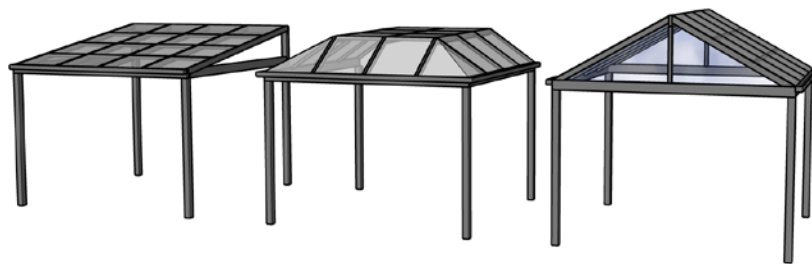

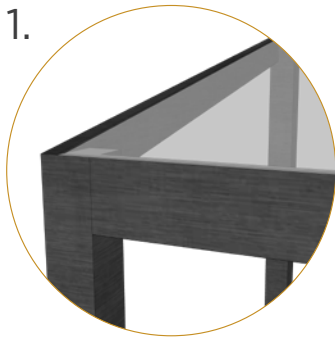

**Commercial Framing**

- Commercial style framing ready for retractable screen installation and adjoined louver zones.
- Internal or external gutters.

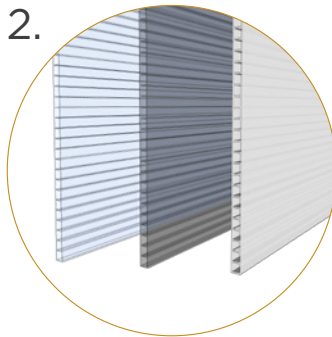

**Polycarbonate**

- 3 Standard color options: Transparent, Tinted and Opaque.
- 10mm fluted polycarbonate.

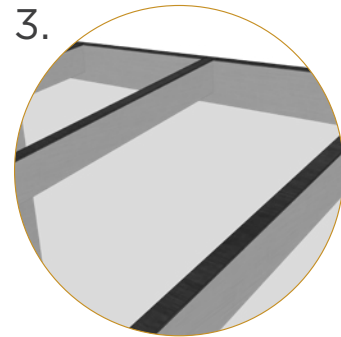

**Stronger Than Glass**

- Durable 10mm polycarbonate glazing.

**Features:**

1. Polycarbonate Roofs provide true weather protection while keeping a space light and bright. They are the best option for a sealed enclosure designed for year round use in colder climates. Adding heaters is a great option for applications such as restaurant patios where you hope to maximise the useability of the space all year.
2. A durable 10mm polycarbonate is used which exceeds the impact resistance of glass while being lightweight and easy to maintain. This UV resistant product won't fade or crack in the sun giving you a long lasting and reliable roof. Gutters can be run on the inside or out of the roof frame depending on design and style needs.









POLYCARBONATE ROOF











POLYCARBONATE ROOF





# | ACCESSORIES

Complete your build with some of our integrated accessories

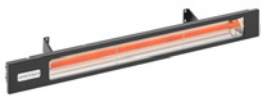

## Heaters

With a variety of options from quality manufactures such as Infratech and Bromic you are able to choose the correct heater to suit your style and needs. Choose from power outputs ranging 1400-6000W.

Heaters are available in 120V and 240v options. Additional products are available from Infratech and Bromic.



## Lighting

Suncoast louvers are designed with a light track integrated into the gutter system for LED rope lights to create an ambient feel.

Pot lights, pendants, mounted fixtures or other third-party lights can also be added.



## Sensors

Rain and wind sensors can be built into the control system of the louvered roofs and retractables. Open and close functions are automated to perform even when you are not around to close everything up in high winds or rain.

Rain and wind sensors can be built in to automate your louver and retractables system. Close the blades and lower the screens as soon as the first few drops land.



## Fans

Not every installation location needs a heater. In many locations, fans are added to keep things cool!

For warmer climates, our framing and accessory beams are designed to handle fan mounting.



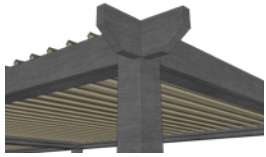

## Architectural Ends

Add architectural ends in either a classic or modern style.



## Cornice Add-on

Cornices add an extra element of architectural intricacy for a bold look.

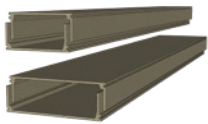

## Accessory Beam

Accessory beams are installed for locations where add-ons are desired but a mounting location is needed. Wiring for accessories can be run inside the beam.



## Smart Home Automation

Suncoast products are designed to be compatible with smart home and automation systems. Use the app to control you screens and louvers from anywhere or take advantage of voice activation through Google or Alexa.



## RollApp Hub

This hub gives you the ability to download the Rollapp and control your louvered roof or retractable screens from your phone.



## LinkIT

This hub is used to integrate your louvered roof or screens to an existing home automation system.



## Dry Contact

This hub is also used to integrate your louvered roof or screens to an existing home automation system.



# Manufacturing

Every single Suncoast retractable is fully custom built to the dimensions of your opening. Careful on-site measurements are taken to the manufacturing facility to build the exact width and drop that will be needed. We will even account for the slope of the floor surface so that the bottom bar contacts across the entire width. Our state of the art CNC machinery and RF welding equipment allow for the industries most precise and high quality manufacturing.





# In House Powder Coating Process

Suncoast now ensures the quality and color availability of our coatings by controlling this process in house with a state of the art powder coating line. Using premier powder coating materials and a highly regulated application procedure, we provide our customers with the best finish available in terms of consistency, durability, and resistance to the elements. Our powder coating standards exceed most area requirements and meet even the most demanding ones with a AAMA 2604 rating.







## | THE TEAM

The people who make everything happen.

Our manufacturing team is the best in the industry because of their commitment to quality, efficiency, and customer satisfaction. With years of experience and a passion for innovation, they consistently produce products that meet the highest standards of excellence. Their advanced technology and attention to detail ensure that every product is manufactured to exact spec-

ifications and delivered on time. Furthermore, they maintain a strong culture of continuous improvement, regularly evaluating and updating their processes to stay ahead of the competition. With our manufacturing team at the forefront of the industry, we are able to provide our customers with exceptional products and service.



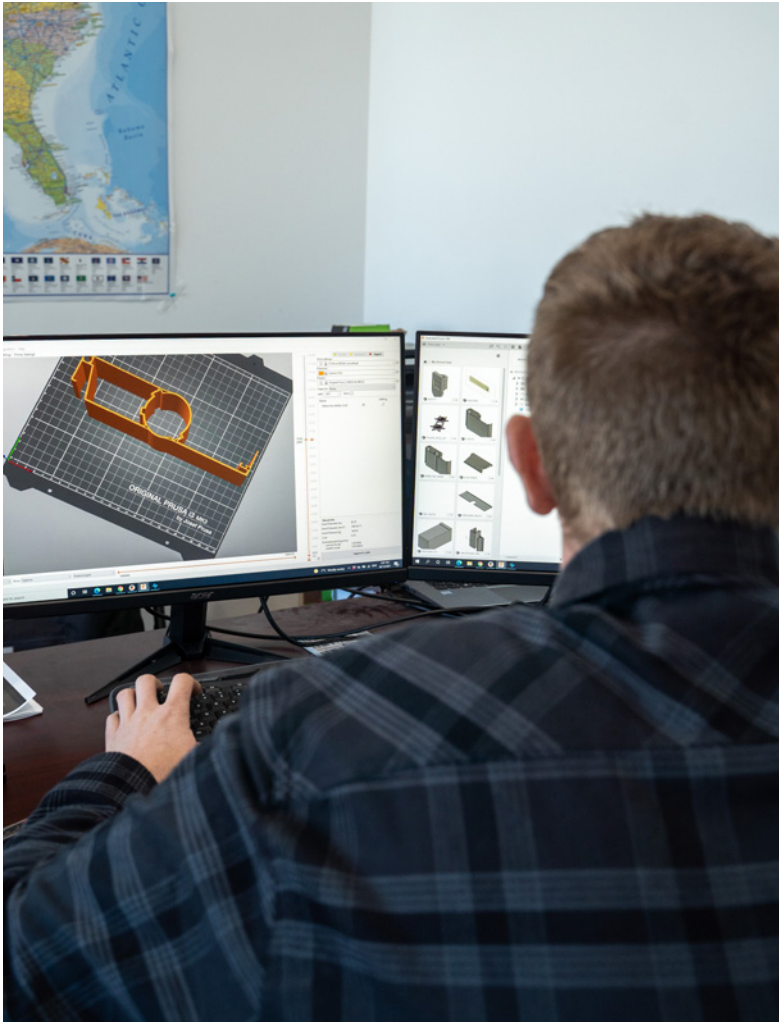





SUNCOAST

+1 877 449 5106 | [suncoastenclosures.com](http://suncoastenclosures.com)