



SUNCOAST

LOUVERED ROOF



BETTER
OUTDOOR
LIVING

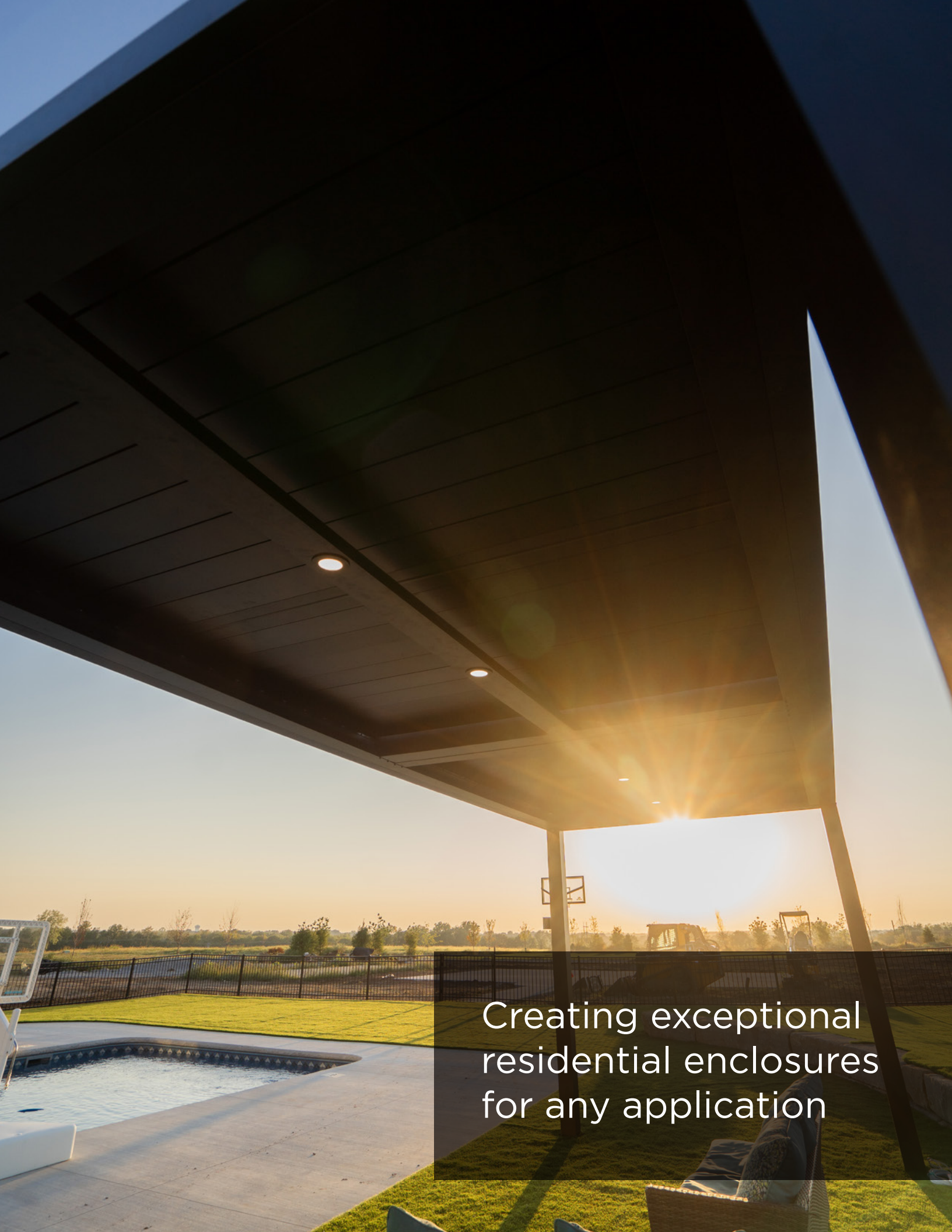

Creating exceptional
residential enclosures
for any application

| TABLE OF CONTENTS

04 ABOUT US

06 PRODUCT: LOUVERED ROOF

17 ACCESSORIES

19 MANUFACTURING

20 POWDER COATING

21 THE TEAM



| ABOUT US

Pushing the boundaries in luxury outdoor living

Suncoast is a premier manufacturer, supplier and builder of luxury outdoor enclosures. With over 30 years of experience building in the harshest Canadian environments, you can count on dependable quality for your next deck, patio, enclosure or project.

MANUFACTURING

Suncoast takes control of the manufacturing process to ensure the highest quality product tailored perfectly to your custom application. From cutting and coating to kitting and shipping, the Suncoast team ensures the reliable delivery of a structure built to last for many years.

PRODUCT DEVELOPMENT

We strive to be at the leading edge of the industry with respect to technology and style. That's why our product development team is continuously sourcing new profiles, parts and smart options to engineer functional and beautiful products.



| LOUVERED ROOF SYSTEM

Enjoy the sunshine with the option of shade on demand

Completely customizable. Maintenance-free. All of our Louvered Roof Systems are designed and engineered to withstand local snow loads and wind speeds.

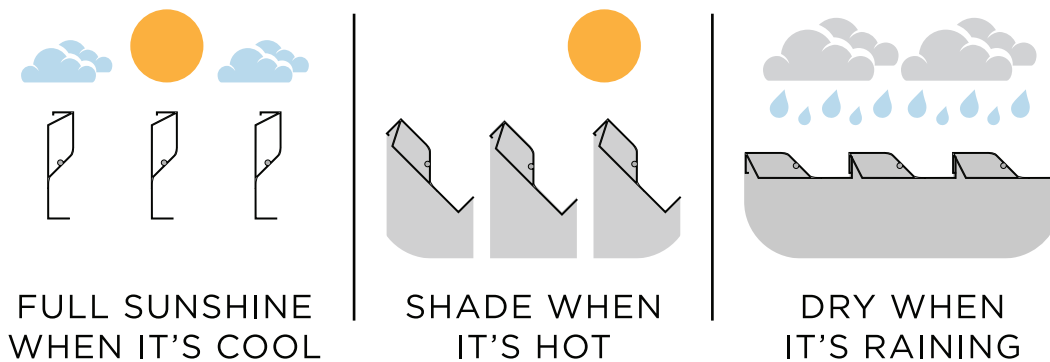

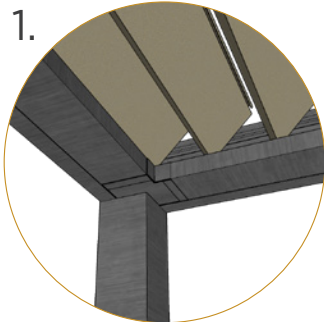
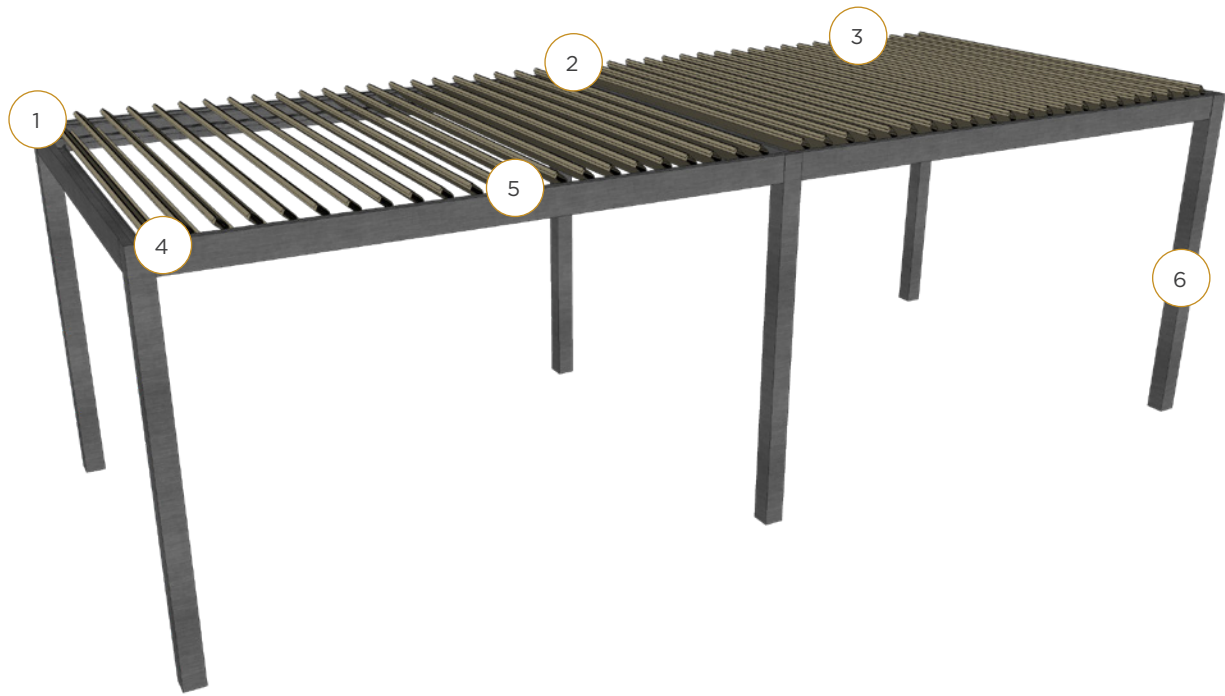

1. All-Aluminum Frame

- Structural grade materials.
- Engineered profiles.

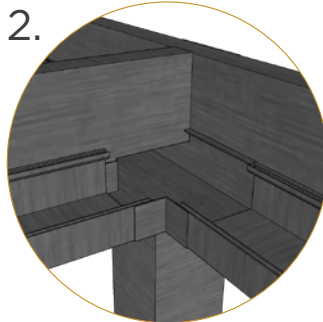

2. Multi-Zone Drainage

- Louver blades drain into internal gutter.
- Unrestricted zone to zone water flow.

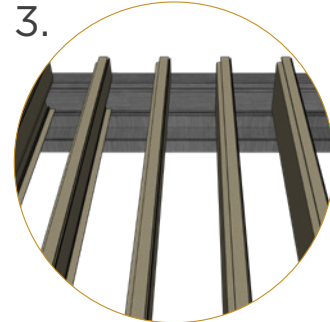

3. Maximum Sunlight

- 8" blade spacing provides industry-leading louver blade opening.

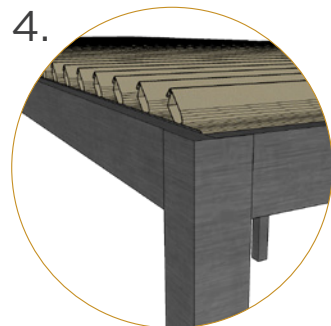

4. Robust Components

- Our 6x6 posts and 2x8 or 4x8 beams are standard.
- Other options available for higher demand situations.



5. Hidden Motor

- A dedicated blade in each zone houses the drive motor.
- No external arms, levers or pistons.

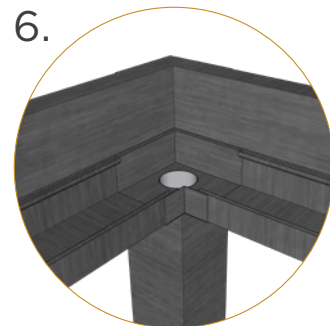

6. Integrated Gutter

- Integrated internal gutter system.
- Gutter fixed internal to frame.
- Downspout hidden inside post.

Frame Specifications and Tolerances

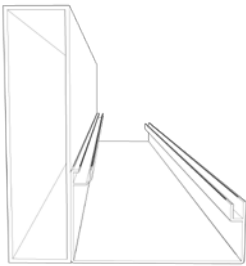

2 x 8 Frame with Internal Gutter

- Span up to 16' between posts.
- The integrated gutter is fastened to the beam and includes chases for motor wiring and ambient light strip.

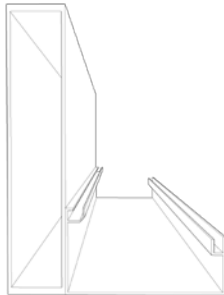

2 x 10 Frame with Internal Gutter

- Span up to 20' between posts.

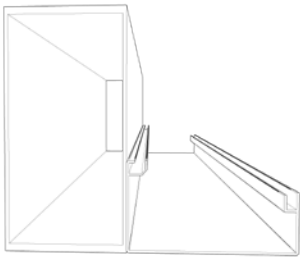

4 x 8 Frame with Internal Gutter

- Span up to 26' between posts.

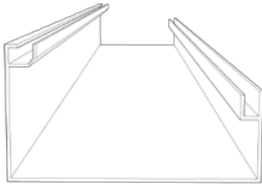

Gutter with Light Track and Wire Chase

- Louver Gutter with optional built-in LED light strip.

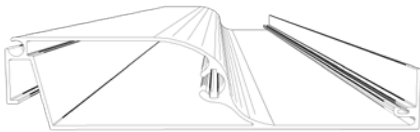

Louver Blade

- Depending on local snow load ratings, blades can span up to 15'.
- Weather stripping on each blade ensures a tight seal and a quiet interface.

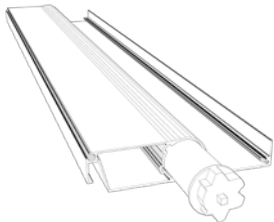

Louver Motor Blade

- A Motor Blade houses the High Torque, Italian-made Gapos motor. Motors and electrical components are CSA approved.
- Control up to 225 sqft with one motor.

Color Options

Suncoast offers 3 stylish standard powder coating colour options as well as any custom color which can be found in the RAL pallet. Special order on textures and prints such as wood grain are also available.



Black



Brown

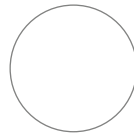

White



Custom



We are pleased to offer our Industry-Leading Limited Lifetime Warranty. For more information please visit our website at suncoastenclosures.com



| LOUVERED ROOF SYSTEM

We know the best results come from bold ideas. Our Louvered Roof System pushes the boundaries of innovation, durability and dependability

INDUSTRIAL STRENGTH

Industrial strength structural aluminum is used on our framing extrusions to ensure the most dependable and sturdy structures on the market. Our 6x6 posts and 2x8 or 4x8 beams are standard with other options available for higher demand situations. Sun-coast louver blades are the widest available at 8 inches and can span an impressive 15 feet.

DRAINAGE

Each louver zone is surrounded by a gutter system fastened to the beam with a seamless look. When louver blades are in the closed position, water is directed to the perimeter of the zones where it flows to the desired drainage location. Downspouts can be hidden inside the structural post.

FLEXIBILITY

Suncoast boasts one of the largest blade widths on the market, letting in more light when open than other systems. Keep the sun shining through by adjusting the blades through a range up to 140 degrees which is controlled either from a remote or the app on a phone or tablet. Smart connectivity is standard on commercial projects so that key people will always be able to operate the Louvered Roof System.

CUSTOMIZATION

Suncoast Louvered Roofs are designed to be accessorized! Auxiliary beams and conduit spaces can be added for mounting and wiring of just about anything. Heaters, lights, fans and AV components are common additions made to enhance the space and further increase the amount of time you can fully utilize the area. Pair a Louvered Roof with Retractable Screens in mesh or vinyl to up the functionality even more!

| LOUVERED ROOF SYSTEM

Some highlights of work we've done for forward-thinking clients

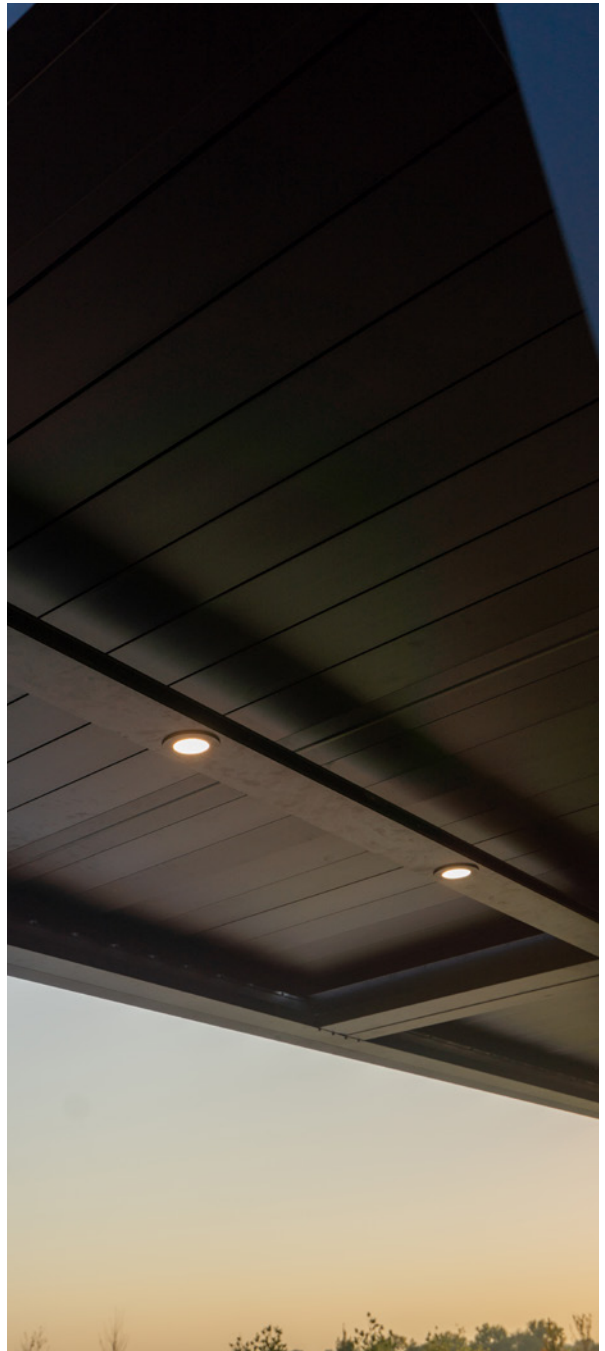





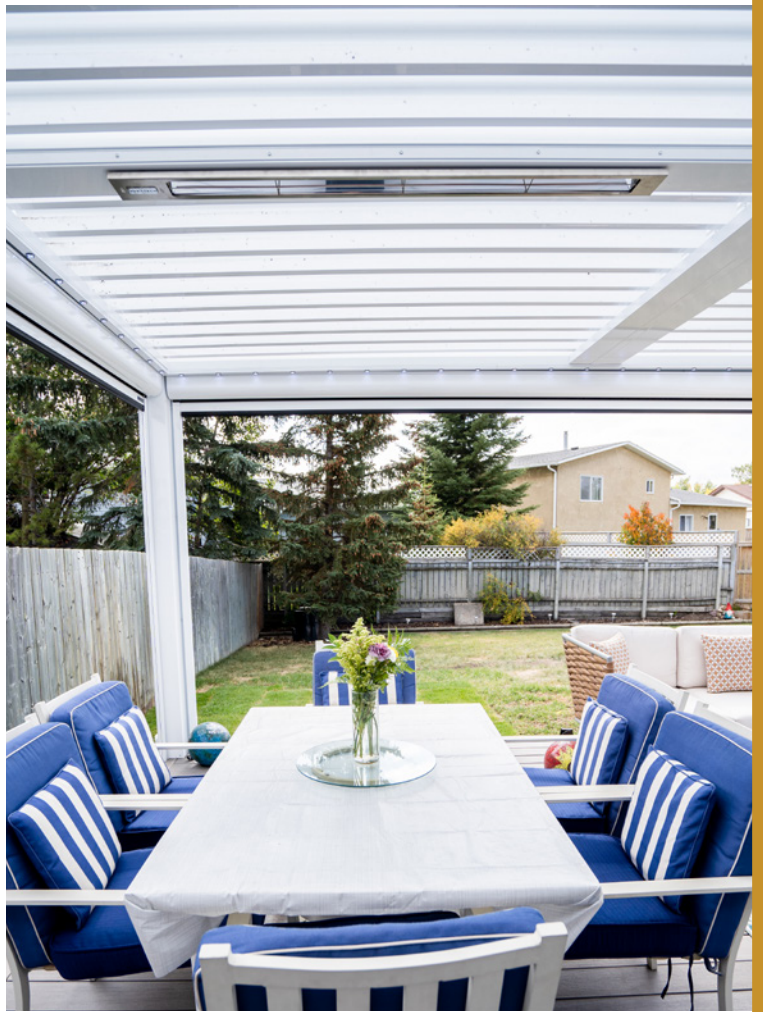



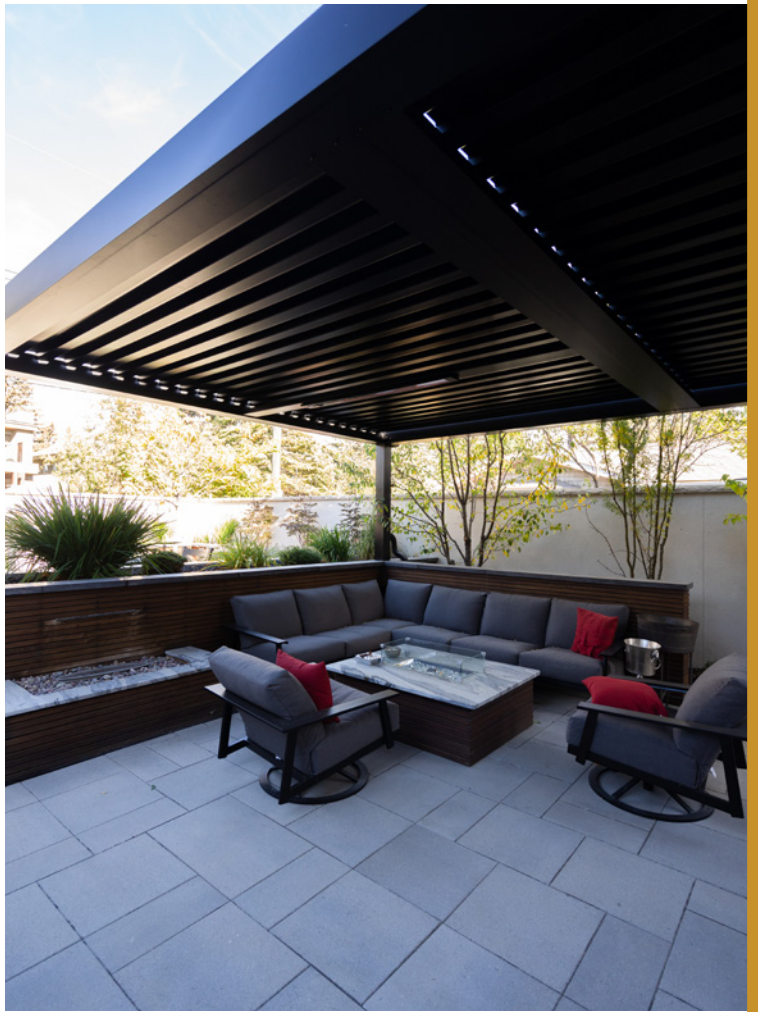

| ACCESSORIES

Complete your build with some of our integrated accessories

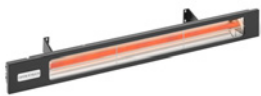

Heaters

With a variety of options from quality manufactures such as Infratech and Bromic you are able to choose the correct heater to suit your style and needs. Choose from power outputs ranging 1400-6000W.

Heaters are available in 120V and 240v options. Additional products are available from Infratech and Bromic.



Lighting

Suncoast louvers are designed with a light track integrated into the gutter system for LED rope lights to create an ambient feel.

Pot lights, pendants, mounted fixtures or other third-party lights can also be added.



Sensors

Rain and wind sensors can be built into the control system of the louvered roofs and retractables. Open and close functions are automated to perform even when you are not around to close everything up in high winds or rain.

Rain and wind sensors can be built in to automate your louver and retractables system. Close the blades and lower the screens as soon as the first few drops land.



Fans

Not every installation location needs a heater. In many locations, fans are added to keep things cool!

For warmer climates, our framing and accessory beams are designed to handle fan mounting.

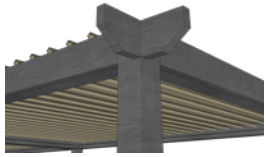

Architectural Ends

Add architectural ends in either a classic or modern style.



Cornice Add-on

Cornices add an extra element of architectural intricacy for a bold look.

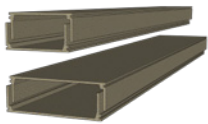

Accessory Beam

Accessory beams are installed for locations where add-ons are desired but a mounting location is needed. Wiring for accessories can be run inside the beam.



Smart Home Automation

Suncoast products are designed to be compatible with smart home and automation systems. Use the app to control you screens and louvers from anywhere or take advantage of voice activation through Google or Alexa.



RollApp Hub

This hub gives you the ability to download the Rollapp and control your louvered roof or retractable screens from your phone.



LinkIT

This hub is used to integrate your louvered roof or screens to an existing home automation system.



Dry Contact

This hub is also used to integrate your louvered roof or screens to an existing home automation system.

Manufacturing

Every single Suncoast retractable is fully custom built to the dimensions of your opening. Careful on-site measurements are taken to the manufacturing facility to build the exact width and drop that will be needed. We will even account for the slope of the floor surface so that the bottom bar contacts across the entire width. Our state of the art CNC machinery and RF welding equipment allow for the industries most precise and high quality manufacturing.



In House Powder Coating Process

Suncoast now ensures the quality and color availability of our coatings by controlling this process in house with a state of the art powder coating line. Using premier powder coating materials and a highly regulated application procedure, we provide our customers with the best finish available in terms of consistency, durability, and resistance to the elements. Our powder coating standards exceed most area requirements and meet even the most demanding ones with a AAMA 2604 rating.





| THE TEAM

The people who make everything happen.

Our manufacturing team is the best in the industry because of their commitment to quality, efficiency, and customer satisfaction. With years of experience and a passion for innovation, they consistently produce products that meet the highest standards of excellence. Their advanced technology and attention to detail ensure that every product is manufactured to exact spec-

ifications and delivered on time. Furthermore, they maintain a strong culture of continuous improvement, regularly evaluating and updating their processes to stay ahead of the competition. With our manufacturing team at the forefront of the industry, we are able to provide our customers with exceptional products and service.

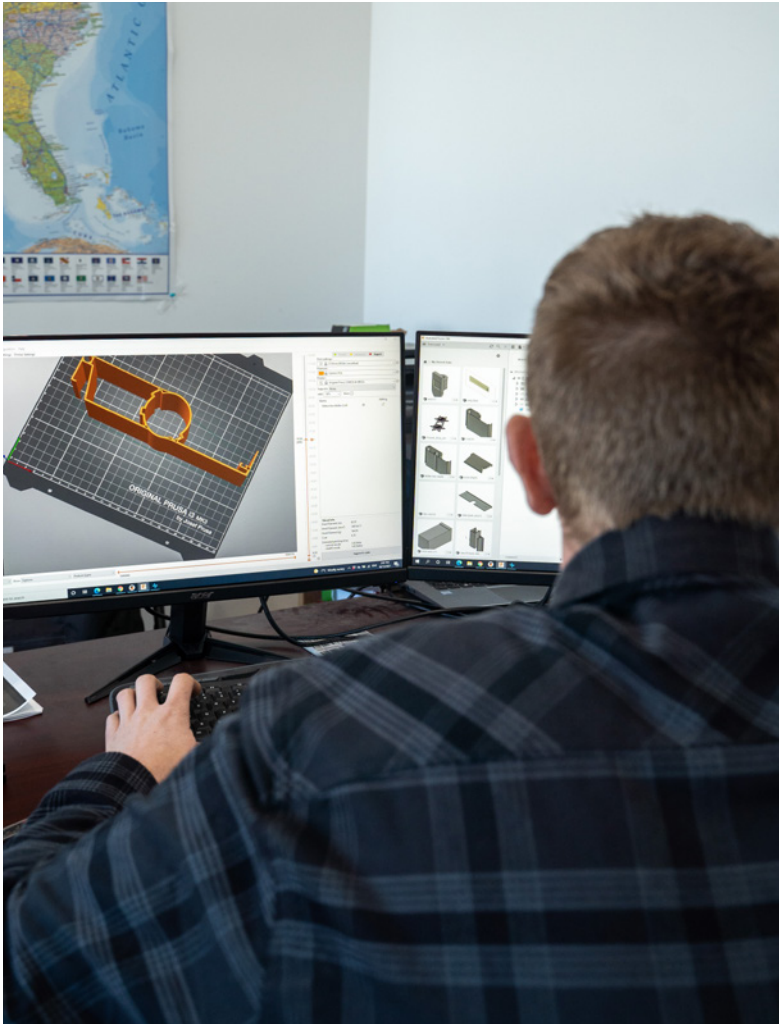



SUNCOAST

+1 877 449 5106 | suncoastenclosures.com